

# Maestro 2.65

Electro-mechanical 2-post lift, 6.5 t capacity



## Application

- Repair and maintenance

## Approvals / recommendations

- Mercedes-Benz
- Volkswagen Group

## Description:

### Posts:

- Symmetric post installation
- Very stable welded posts
- Without base frame
- Two motors
- Cold-rolled spindle
- Nylon nut sets
- Carriage with 6 guiding wheels and lubrication-free roller bearings
- Pushbutton control unit with alarm signal
- Programmable top stop
- Electronic synchronization

### Arms:

- 4 triple telescopic arms
- Wheel bearing of the first extension arm
- Low minimum height

### Standard colours:

- Arms: RAL 3020 – red
- Posts: RAL 7016 – grey

## Versions:

- Available with different voltages
- F = flex pad

## Optional extras:

- Available with portal or in-ground kit
- LED-lighting set
- Power pack
- Set of expansion bolts
- Extra control unit
- Long door stops
- Wheel holders
- Large program of extra pads

**Special colours available on request!**



Scan the QR-Code for detailed product information.

Further Information on [www.autopstenhoj.com](http://www.autopstenhoj.com)

**AUTOPSTENHOJ GmbH**

Sandkampstraße 90  
D-48432 Rheine  
☎ +49 5971 8602-02  
✉ [info@autopstenhoj.com](mailto:info@autopstenhoj.com)

**AUTOPSTENHOJ GmbH**

Barrit Langgade 188-190  
DK-7150 Barrit  
☎ +45 76 82 13 30  
✉ [info@autopstenhoj.com](mailto:info@autopstenhoj.com)

Technical data	
Lifting capacity	6,500 kg
Lifting height	1,900 mm
Working height	2,045 – 2,105 mm
Lifting / lowering time	approx. 35 sec.
Motor	2 x 4 kW
Voltage	3 x 230 / 400V – 50 Hz – 35 / 25 A

Arm superstructure	
Lifting pad included in the delivery	F: 11028 (90 – 150 mm)
Min. height	145 mm
Drive-through width	2,829 mm
Width between posts	3,170 mm
Total width - outer edges posts	3,560 mm
Total width - outer edges base plates	4,000 mm
Total height post	2,908 mm
Total height incl. portal	4,910 – 5,270 mm
Arm length front, min. - max.	770 – 1,640 mm
Arm length rear, min. - max.	770 – 1,640 mm

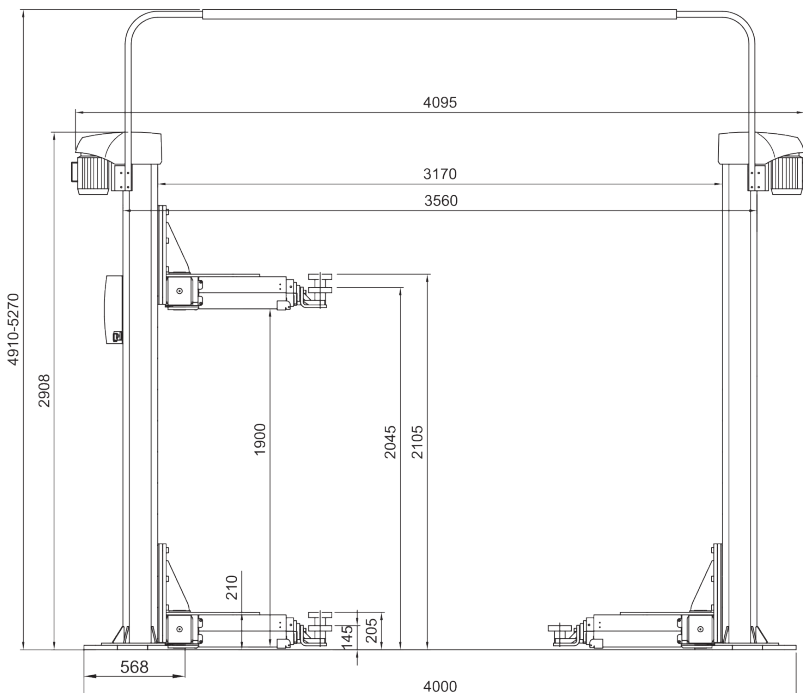

Triple telescopic arms with F-pad



Stable, welded post



Carriage with rollers